



@ANY900-2

868/915MHz *IEEE802.15.4 RF UFL Module*

May 14, 2010
A.N. Solutions GmbH
Am Brauhaus 12
01099 Dresden



Content

1 GENERAL.....	3
1.1 APPLICATIONS.....	3
1.2 KEY FEATURES.....	3
2 OVERVIEW.....	4
2.1 ELECTRICAL CHARACTERISTICS.....	5
2.1.1 ABSOLUTE MAXIMUM RATINGS.....	5
2.1.2 RF CHARACTERISTICS.....	5
2.1.3 MICROCONTROLLER CHARACTERISTICS.....	6
2.2 PHYSICAL/ENVIRONMENTAL CHARACTERISTICS AND OUTLINE.....	6
2.3 MOUNTING INFORMATION.....	8
2.4 SOLDERING PROFILE.....	10
2.5 TYPICAL REFERENCE SCHEMATIC.....	11
3 ORDERING INFORMATION.....	12



1 General

@ANY900-2 is a full featured ultra-low power IEEE 802.15.4 based RF module for European and North American Sub-1 GHz ISM bands that support ZigBee™ and 6LoWPAN applications. This cutting edge module combines an exceptional receiving sensitivity and an optimal output power level in the smallest form factor. @ANY900 is a fully integrated solution that contains all the digital and analog circuitry, required for the tiny radio nodes along to U.FL connection providing maximum flexibility of external antenna adaptations. The module eliminates the need for costly and time-consuming RF development, and shortens time to market for a wide range of standards based wireless products.

1.1 Applications

@ANY900-2 is a flexible tool that can help realizing standard or specialized functionality by usage of different stack layers. The module provides ideal solutions for the following markets:

- Building automation and monitoring
- HVAC and environmental control
- Security applications
- AMR/AMI

These and many other applications are realized using the following network topologies:

Point-2-Point communication

For point-2-point radio links, the application normally uses the HAL layer (Hardware Abstraction Layer) only and utilizes the maximum MCU flash and RAM. It can also assess the radio on register level for squeezing out the optimal performance.

Star communication

Star or Point-2-Multipoint networks require some addressing scheme and a tight protocol to realize additional functionality, such as:

- Checksum proven and acknowledged data frame transmission
- Automatic frame retransmission
- Automatic children addressing

Mesh communication

Mesh networks can be realized with the help of Atmel's BitCloud ZigBee PRO Feature Set. In a mesh network the addressing of all network nodes is done by the network layer in order to allow direct or relayed communication with all nodes in the network. Route detection and frame delivery is supported following the AODV algorithm (Ad-hoc On-demand Distance Vector).

1.2 Key features

- Compact size (40.5 x 14.5 mm)
- Receiver sensitivity (-110 dBm)
- Up to 10 dBm scalable output power
- Low power consumption (< 6 µA in Sleep mode)
- 128K bytes of flash memory, 8K bytes RAM, 4K bytes Eeprom
- Supply monitoring via ADC
- Wide range of interfaces (both analog and digital):
 - 9 spare GPIO, 2 spare IRQ lines
 - 4 ADC lines
 - UART and USART



- TWI
- SPI
- 1-Wire
- Up to 30 lines configurable as GPIO
- Capability to write own MAC address into the EEPROM
- IEEE 802.15.4 compliant
- 868 / 915 MHz band (antenna option)
- Runs BitCloud (Zigbee Pro Feature Set) unchanged
- Support other 3rd party SW solutions for 6LoWPAN applications
- Additional 2Mbit flash for storing two MCU flash images
- Compatible with Atmel's module platform for ZigBee Pro
- Compliant to radio certification standard EN300220 ⁽¹⁾
- RF port available on UFL connector
- Current Consumption
 - TX: <33mA @10dBm
 - RX: <17mA
 - Idle: 9.5mA
 - Sleep: <6uA

⁽¹⁾ Certification planned

2 Overview

The @ANY900-2 module contains Atmel microcontroller (Atmega1281V), IEEE802.15.4 radio (AT86RF212) and serial data flash, which can store two flash images of the used MCU. The module is equipped with U.FL connector for maximum flexibility of external antenna adaptation. Several ports are routed to the edge of the module's carrier PCB, such as GPIOs, power connections, and more. See Figure 1 for an overview of the module's contents.

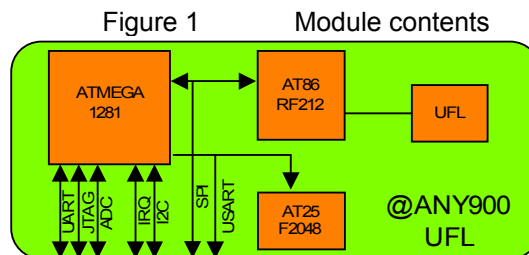

By default, the module is sold without the downloadable firmware "Smart MAC Suite" SMS-Base from www.an-solutions.de. Different delivery options may be realized on dedicated customer demand.



2.1 Electrical Characteristics

2.1.1 Absolute Maximum Ratings

Table 1 Absolute maximum ratings (for VCC=3.3V)

Parameters	Min	Max
Voltage on any pin, except RESET with respect to Ground	-0.5V	V _{CC} +0.5V
DC Current per I/O Pin		40 mA
DC Current DVCC and DGND pins		300 mA
Input RF Level		+5 dBm

Notes:

- Values stated in Table 2 are such values, when the device may be damaged permanently if exposed to them. The device will not work correctly at the given values or beyond.
- The @ANY900 device is ESD-sensitive. Handle carefully to prevent ESD damages!

2.1.2 RF Characteristics

Table 2 RF characteristics

Parameters	Range	Unit
Frequency Band	868 to 868.6 902 to 928	MHz
Number of Channels EU (ISM868)	1	
Number of Channels USA (ISM915)	10	
Channel Spacing USA	2MHz	
Transmitter Output Power (SW controllable)	-24 to +3	dBm
<i>Receiver Sensitivity, AWGN channel, PER = 1%:</i>		
<i>With PSDU length of 20 octets</i>		
20 kbit/s ⁽²⁾	-110	dBm
40kbit/s ⁽²⁾	-108	dBm
100 kbit/s ⁽²⁾	-101	dBm
250 kbit/s ⁽²⁾	-100	dBm
<i>With PSDU length of 127 octets</i>		
200 kbit/s	-97	dBm
400 kbit/s	-90	dBm
500 kbit/s	-97	
1000 kbit/s	-92	dBm



<i>On-Air Data Rate</i>		
BPSK modulation 868.3MHz	20	kbps
BPSK modulation 915MHz	40	kbps
O-QPSK modulation ISM868	100 250	kbps
O-QPSK modulation ISM915	250	kbps
TX Output/ RX Input Nominal Impedance For balanced output	50	Ω
Range, outdoors ⁽¹⁾ , for balanced output	6	km

Notes:

⁽¹⁾ Preliminary data

⁽²⁾ IEEE 802.15.4-2006 compliant

2.1.3 Microcontroller Characteristics

Table 3 Microcontroller characteristics

Parameters	Range	Unit
On-chip Flash Memory size	128	Kbytes
On-chip RAM size	8	Kbytes
On-chip EEPROM size	4	Kbytes
Operation Frequency	8	MHz

2.2 Physical/Environmental Characteristics and Outline

Table 4 Environmental characteristics

Parameters	Value	Comments
Size	40.5 x 14.5 x 3.0 mm	AT-ANY900-2
Operating Temperature Range	-20°C to +70°C	-40°C to +85°C operational ⁽¹⁾
Operating Relative Humidity Range	no more than 80%	

Note: ⁽¹⁾ Minor degradation of clock stability may occur.

Figure 2 @ANY900 Mechanical drawing

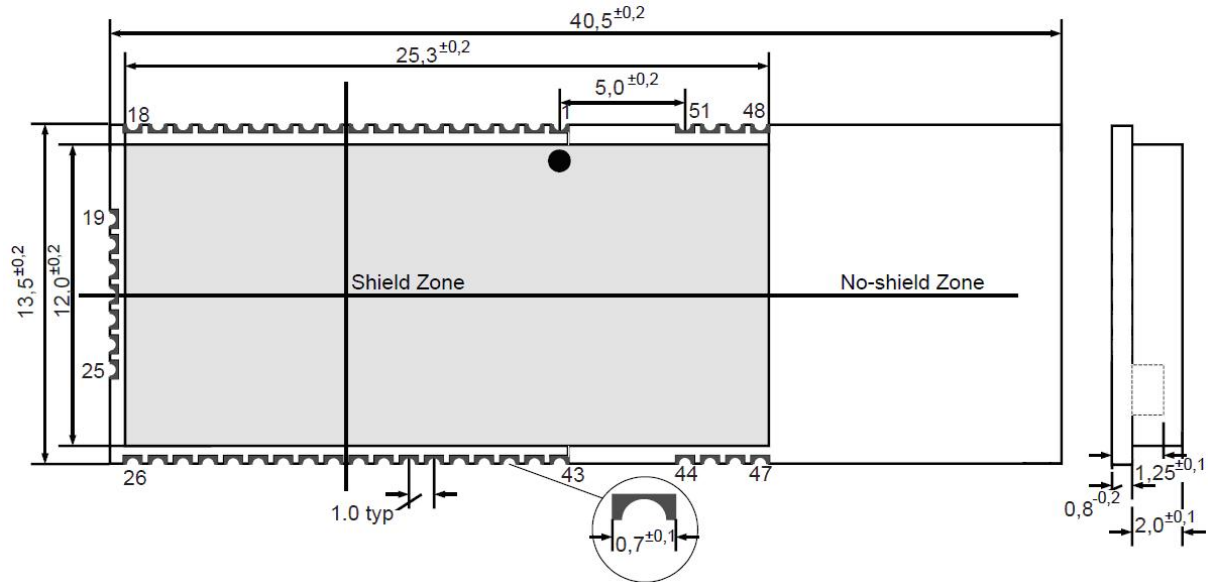

Table 5 Pin description

#	I/O	Description	#	I/O	Description
1	O	SPI_SCLK	27	I	JTAG_TDI
2	I/O	SPI_MISO	28	O	JTAG_TDO
3	I/O	SPI_MOSI	29	I	JTAG_TCK
4	I/O	GPIO0	30	I	ADC_INPUT3
5	I/O	GPIO1	31	I	ADC_INPUT2
6	I/O	GPIO2	32	I	ADC_INPUT1
7	O	OSC32K_OUT	33	I	ADC_INPUT0
8	I	RESET	34	I/O	A_VREF
9		DGND	35		AGND
10	O	CPU_CLK	36	I/O	1WR
11	O	I2C_CLK	37	I	UART_DTR
12	I/O	I2C_DATA	38	O	USART0_TXD
13	I	UART_TXD	39	I	USART0_RXD
14	O	UART_RXD	40	I	USART0_EXTCLK
15	I	UART_RTS	41	I/O	GPIO8
16	O	UART_CTS	42	I	IRQ7
17	I/O	GPIO6	43	I	IRQ6
18	I/O	GPIO7	44		GND
19	I/O	GPIO3	45		GND



20	I/O	GPIO4	46		D_VCC
21	I/O	GPIO5	47		D_VCC
22		GND	48		D_VCC
23		GND	49		D_VCC
24		D_VCC	50		GND
25		D_VCC	51		GND
26	I	JTAG_TMS			

Notes:

- The UART_TXD pin shall be used as data input for using @ANY900 as its RF terminal unit. UART_RXD pin shall operate as output.
- Most signals can be configured as I/O pins with or without internal pull-up resistor.
- Using ferrite bead and 1 μ F capacitor located closely to the power supply pin is recommended.

2.3 Mounting Information

Figure 3 @ANY-BRICK PCB picture as a reference for applications

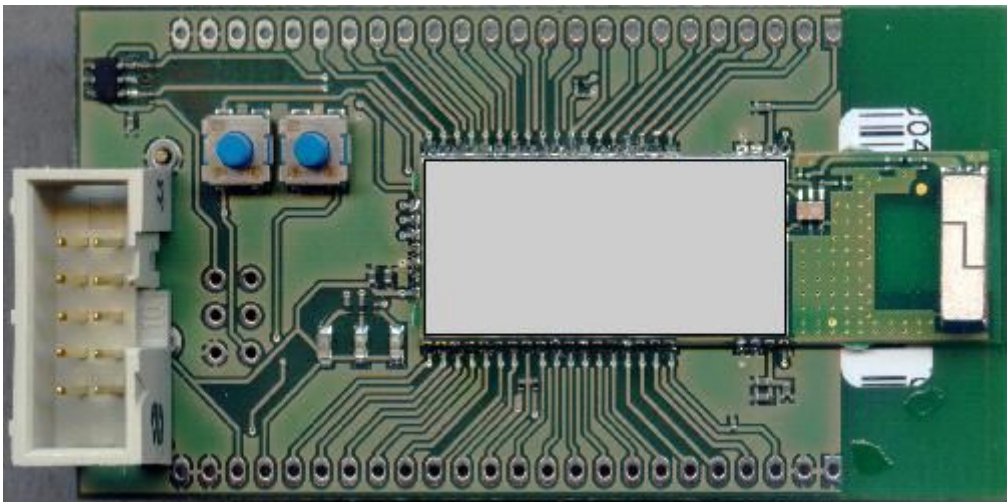

Several factors may affect the proper operation, such as the environment surrounding the module and especially the antenna. The module's antenna is a ceramic design, which provides a radiating structure if the environment and design does not change the near-field of the antenna with metallic or capacitive elements. The critical area is limited by about two to four wavelengths, which is roughly in a radius of 1.5 meters.

Following these tips will improve the radiating performance:

- Avoid metal as much as possible
- Avoid placing high profiled elements close to the antenna
- Placing many thin vias through all the carrier PCB connecting metal to ground helps avoid resonance effects and provide a low impedance connection to ground potential
- Place RF parts far off from switching circuitry to avoid intermodulations
- Metalize board edges on top and bottom layer and place vias there to connect the layers for eliminating board edge radiations

For a proper PCB layout:

- Keep fast switching signals as far away as possible from the non-shielded area (right side from the AT86RF212)
- Remove any metal below and around the antenna section
- Place the module at the edge of your carrier board
- Use ferrite beads on power supply lines for proper and stable RF radiation
- Vias and wires below the module are NOT allowed
- Connect RF ground pins to low ohmic ground, place vias right next to the pin connection if needed

Figure 4 Pad layout

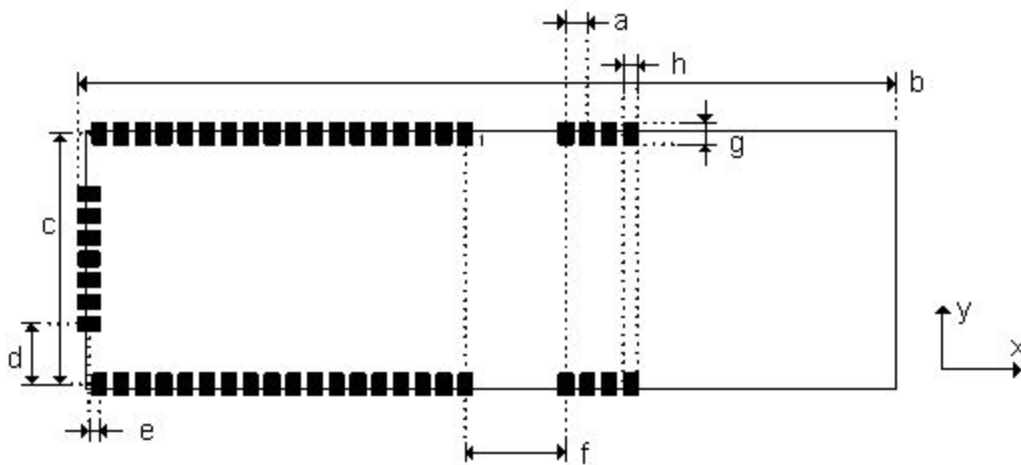

All values in [mm]

a	1	distance from pad to pad (center)
b	41	module's x dimension
c	13,2	pad center to pad center in y direction (pin 18 to pin 26)
d	3,6	pad centers y distance (pin 25 to pin 26 and pin 18 to pin 19)
e	0,75	pad centers x distance (pin 25 to pin 26 and pin 18 to pin 19)
f	5	pad center distance (pin 43 to pin 44 and pin 1 to pin 57)
g	1	pad size in y direction
h	0,8	pad size in x direction



2.4 Soldering Profile

The J-STD-020D-compliant soldering profile is recommended.

Table 6 J-STD-020D Profile

Feature	Green Package
Average ramp-up rate (217 °C to peak)	3 °C/s max.
Preheat temperature 175 °C ± 25 °C	180 s max.
Temperature maintained above 217 °C	60 s to 150 s
Time within 5 °C of actual peak temperature	20 s to 40 s
Peak temperature range	8 minutes max.
Ramp-down rate	6 °C/s max.

Note: The package is backward compatible with Pb/Sn soldering profile

Figure 5 EMS Reference soldering profile

SuperM.O.L.E.(r) Gold SPC V5.22aa - kundenspez_Profile.mpc
Id. Datei: SM_E91824_000104 Datum: 24/01/07

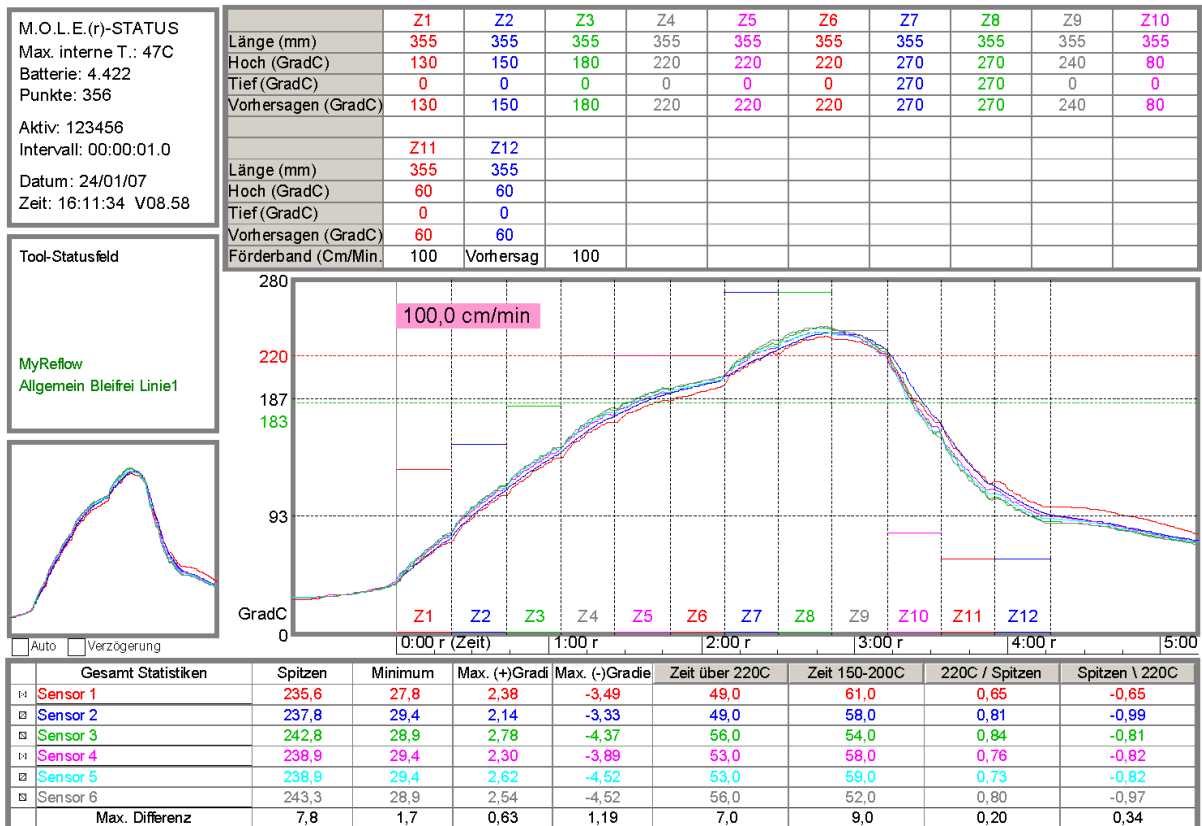

2.5 Typical Reference Schematic

Figure 6 @ANY-BRICK schematic as a reference

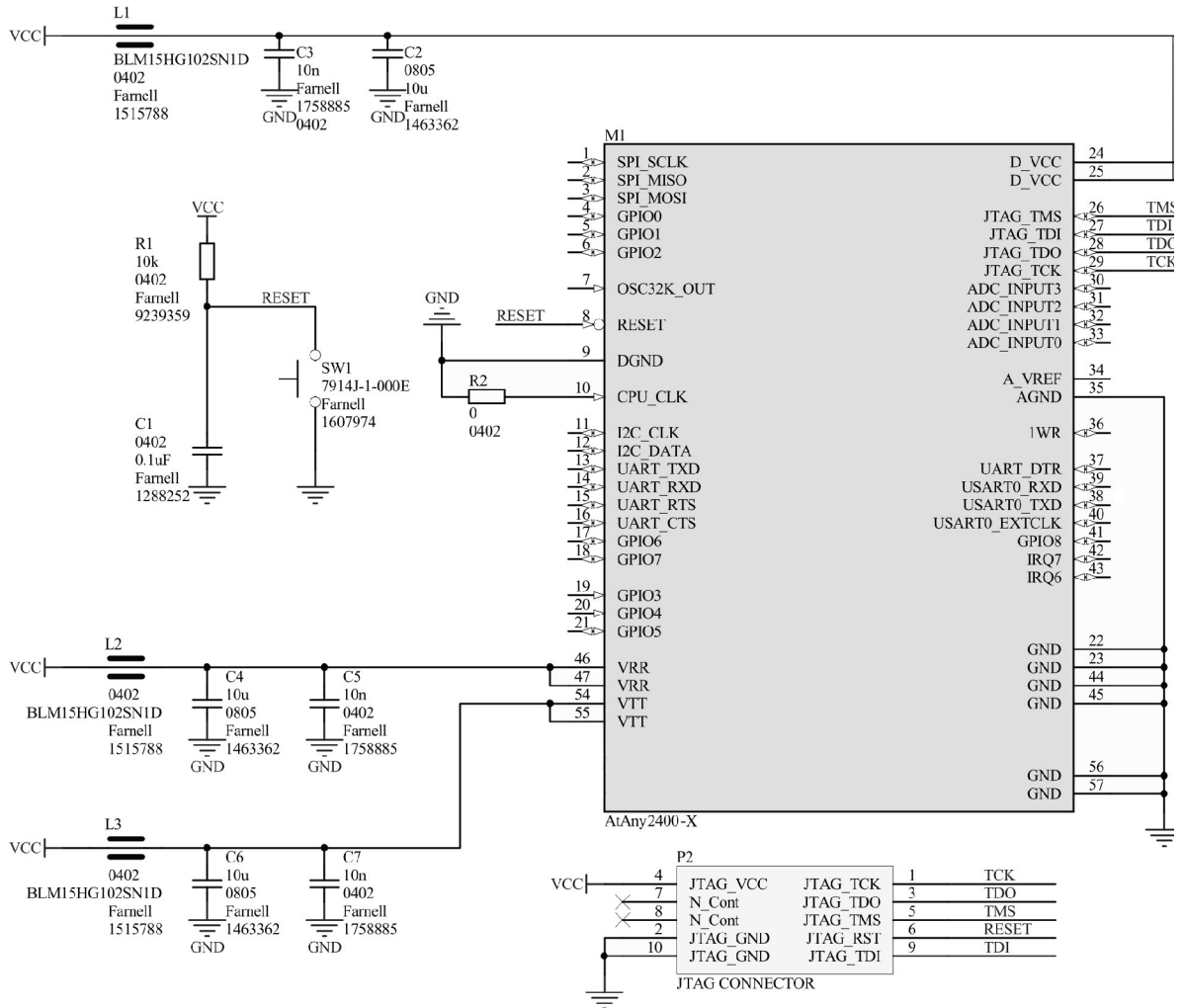



3 Ordering Information

Part number: @ANY900-2
Description: IEEE802.15.4-868/915MHz UFL module
Shipping variants: On request

Disclaimer

A.N. Solutions believes that all information is correct and accurate at the time of issue. A.N. Solutions reserves the right to make changes to this product without prior notice. Please visit A.N. Solutions website for the latest available version.

A.N. Solutions does not assume any responsibility for the use of the described product or convey any license under its patent rights.

A.N. Solutions warrants performance of its hardware products to the specifications applicable at the time of sale in accordance with A.N. Solutions standard warranty. Testing and other quality control techniques are used to the extent A.N. Solutions deems necessary to support this warranty. Except where mandated by government requirements, testing of all parameters of each product is not necessarily performed.

Trademarks

AT-ANY, @ANY and related namings as well as A.N. Solutions logo are trademarks of A.N. Solutions GmbH. All other product names, trade names, trademarks, logos or service names are the property of their respective owners.

Technical Support

Technical support is provided by A.N. Solutions GmbH on demand and in accordance to service conditions agreed.

E-mail: support@an-solutions.de

Please refer to Support Terms and Conditions for full details.

Contact Information

A.N. Solutions GmbH

Am Brauhaus 12
01099, Dresden,
Germany
Tel: +49 351 8134 228
Fax: +49 351 8134 200

Office hours: 8:00am - 5:00pm (Central European Time)

© 2011 A.N. Solutions All rights reserved.

No part of the contents of this manual may be transmitted or reproduced in any form or by any means without the written permission of A.N. Solutions.