



**ADAPTIVE NETWORK**

**SOLUTIONS**

... smarter wireless connectivity

---

# @ANY2400-2

*2.4GHz*

*IEEE802.15.4 RF Module*

2011-May-04

A.N. Solutions GmbH

Am Brauhaus 12

01099 Dresden



## Content

1 GENERAL.....	3
1.1 APPLICATIONS.....	3
1.2 KEY FEATURES.....	4
2 OVERVIEW.....	4
2.1 ELECTRICAL CHARACTERISTICS.....	5
2.1.1 ABSOLUTE MAXIMUM RATINGS.....	5
2.1.2 RF CHARACTERISTICS.....	5
2.1.3 MICROCONTROLLER CHARACTERISTICS.....	6
2.2 PHYSICAL/ENVIRONMENTAL CHARACTERISTICS AND OUTLINE.....	6
2.3 MOUNTING INFORMATION.....	8
2.4 SOLDERING PROFILE.....	10
2.5 TYPICAL REFERENCE SCHEMATIC.....	11
2.6 SOFTWARE AND PROGRAMMING OPTIONS.....	12
3 ORDERING INFORMATION.....	13



# 1 General

@ANY2400-2 is a full featured ultra-low power IEEE802.15.4/ZigBee RF module for European and North American 2.4 GHz ISM bands. This cutting edge module combines an exceptional receiving sensitivity and an optimal output power level in the smallest form factor. @ANY2400-2 is a fully integrated solution that contains all the digital and analog circuitry, required for the tiny radio nodes best suited for installation of low power wireless sensor network (WSN) solutions. The module eliminates the need for costly and time-consuming RF development, and shortens time to market for a wide range of standards based wireless products due to seamless scalability of provided interfaces.

## 1.1 Applications

@ANY2400-2 module is a flexible tool that can help realize standard, proprietary or customized functionality by utilizing different stack layers. The module provides ideal solutions for the following markets:

- Building automation and monitoring
- HVAC and environmental control
- Security applications
- AMR/AMI
- Logistics & Asset tracking
- Medical

These and many other applications are realized using the following network topologies:

### *Point-To-Point communication*

For point-to-point radio links, the application normally uses the HAL layer (Hardware Abstraction Layer) only and utilizes the minimum MCU flash and RAM. It can also assess the radio on register level for squeezing out the optimal performance.

### *Star communication*

Star or Point-to-Multipoint networks require some addressing scheme and a tight protocol to realize additional functionality, such as:

- Checksum proven and acknowledged data frame transmission
- Automatic frame retransmission
- Automatic children addressing

### *Mesh communication*

Mesh networks can be realized with the help of Atmel's BitCloud ZigBee PRO Feature Set. In a mesh network the addressing of all network nodes is done by the network layer in order to allow direct or relayed communication with all nodes in the network. Route detection and frame delivery is supported following the AODV algorithm (Ad-hoc On-demand Distance Vector).



## 1.2 Key Features

- ▲ Compact size (40.5 x 14.5 mm)
- ▲ Receiver sensitivity (-101 dBm)
- ▲ Up to +20dBm scalable output power
- ▲ Low power consumption (< 6  $\mu$ A in Sleep mode)
- ▲ 128K bytes of flash memory, 8K bytes RAM, 4K bytes Eeprom
- ▲ Supply monitoring via ADC possible (external circuit needed)
- ▲ Wide range of interfaces (both analog and digital) available in standard configuration:
  - 9 spare GPIO, 2 spare IRQ lines
  - 4 ADC lines
  - UART and USART
  - TWI
  - SPI
  - 1-Wire
  - Up to 30 lines configurable as GPIO
- ▲ Capability to write own MAC address into the EEPROM
- ▲ IEEE 802.15.4-2006 compliant
- ▲ 2.4 GHz ISM band
- ▲ Runs BitCloud (Zigbee Pro Feature Set) unchanged
- ▲ Additional 2Mbit Serial SPI flash for storing two MCU flash images
- ▲ Compatible with Atmel's module platform for ZigBee Pro
- ▲ 50 Ohms single-ended U.FL connector
- ▲ Compliant to radio certification standard EN300328 <sup>(1)</sup>
- ▲ Current Consumption
  - TX: <70mA @20dBm
  - RX: <20mA
  - Idle: 9.5mA
  - Sleep: <6uA

<sup>(1)</sup> Certification compliance tests in progress

## 2 Overview

The @ANY2400-2 module contains Atmel microcontroller (Atmega1281V), IEEE802.15.4 radio (AT86RF231) and serial SPI flash, which can store two flash images of the used MCU. The module is equipped with an U.FL. connector. Several ports are routed to the edge of the module's carrier PCB, such as GPIOs, power connections, and more. See Figure 1 for an overview of the module's contents.

Figure 1 Module contents

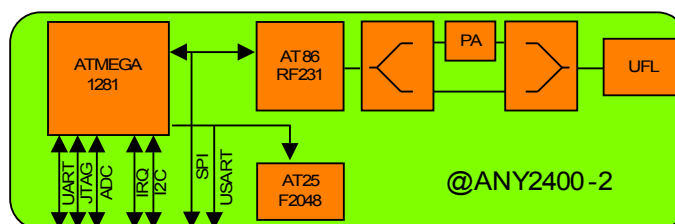

By default, the module is sold without the downloadable firmware "Smart MAC Suite" from [www.ansolutions.de](http://www.ansolutions.de). Different application specific solutions may be provided on customer demand.



## 2.1 Electrical Characteristics

### 2.1.1 Absolute Maximum Ratings

Table 1 Absolute maximum ratings

Parameters	Min	Max
VCC	2.5V	3.6V
Voltage on any pin, except RESET with respect to Ground	-0.5V	VCC+0.5V
DC Current per I/O Pin		40mA
DC Current DVCC and DGND pins		300 mA
Input RF Level		+10 dBm

Notes:

- Values stated in Table 2 are such values, when the device may be damaged permanently if exposed to them. The device will not work correctly at the given values or beyond.
- The @ANY2400-2 device is ESD-sensitive. Handle carefully to prevent ESD damages!

### 2.1.2 RF Characteristics

Table 2 RF characteristics

Parameters	Typical Value	Unit
Operating supply voltage	3.3	V
Frequency Band	2405 ... 2480	MHz
Number of Channels	16	
Transmitter Output Power (SW controllable)	0 ... 20 (+/- 3dB) <sup>(1)</sup>	dBm
<i>Receiver Sensitivity, AWGN channel, PER = 1%, PSDU length = 20 octets:</i>		
250 kbit/s <sup>(2)</sup>	-101	dBm
500kbit/s <sup>(2)</sup>	-97	dBm
1000 kbit/s <sup>(2)</sup>	-95	dBm
2000 kbit/s <sup>(2)</sup>	-89	dBm
<i>On-Air Data Rate</i>	250	kbps

Notes:

<sup>(1)</sup> Measured at Tx/Rx Output Level in CW mode

<sup>(2)</sup> IEEE 802.15.4-2006 compliant

## 2.1.3 Microcontroller Characteristics

Table 3 Microcontroller characteristics

Parameters	Range	Unit
On-chip Flash Memory size	128	Kbytes
On-chip RAM size	8	Kbytes
On-chip EEPROM size	4	Kbytes
Max operation frequency	8	MHz

## 2.2 Physical/Environmental Characteristics and Outline

Table 4 Environmental characteristics

Parameters	Value	Comments
Size	40.5 x 14.5 x 3.0 mm	AT-ANY2400-2
Operating Temperature Range	-20°C to +70°C	-40°C to +85°C operational <sup>(1)</sup>
Operating Relative Humidity Range	no more than 80%	

Note: <sup>(1)</sup> Minor degradation of clock stability may occur.

Figure 2 @ANY2400-2 Mechanical drawing

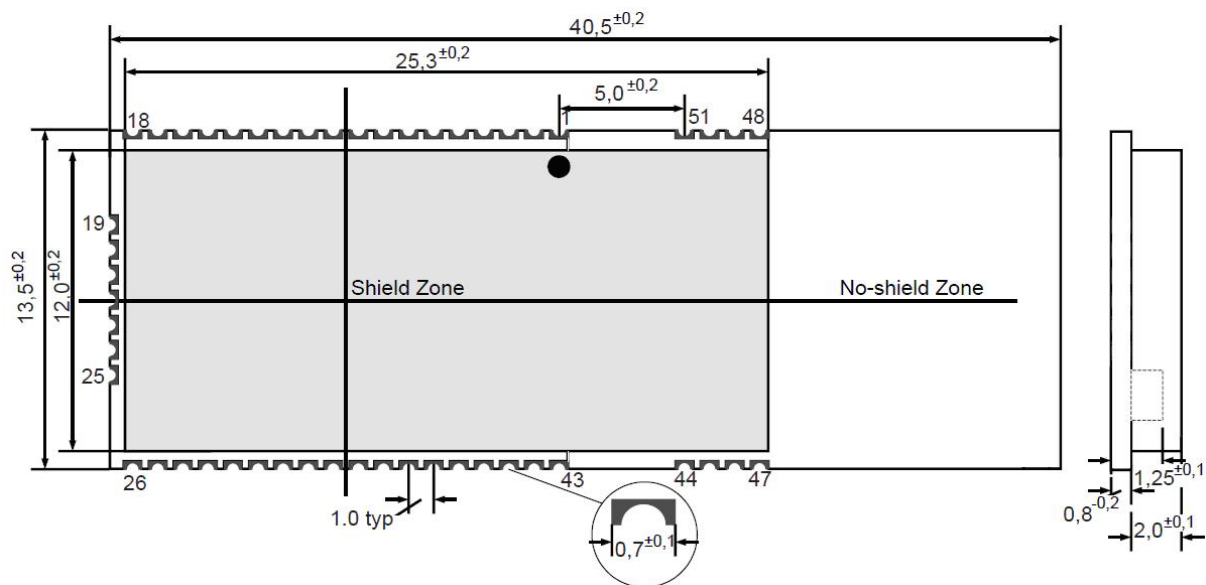



Table 5 Pin description

#	I/O	Description	#	I/O	Description
1	O	SPI_SCLK	27	I	JTAG_TDI
2	I/O	SPI_MISO	28	O	JTAG_TDO
3	I/O	SPI_MOSI	29	I	JTAG_TCK
4	I/O	GPIO0	30	I	ADC_INPUT3
5	I/O	GPIO1	31	I	ADC_INPUT2
6	I/O	GPIO2	32	I	ADC_INPUT1
7	O	OSC32K_OUT	33	I	ADC_INPUT0
8	I	RESET	34	I/O	A_VREF
9		DGND	35		AGND
10	O	CPU_CLK	36	I/O	1WR
11	O	I2C_CLK	37	I	UART_DTR
12	I/O	I2C_DATA	38	O	USART0_TXD
13	I	UART_TXD	39	I	USART0_RXD
14	O	UART_RXD	40	I	USART0_EXTCLK
15	I	UART_RTS	41	I/O	GPIO8
16	O	UART_CTS	42	I	IRQ7
17	I/O	GPIO6	43	I	IRQ6
18	I/O	GPIO7	44		GND
19	I/O	GPIO3	45		GND
20	I/O	GPIO4	46		VRR
21	I/O	GPIO5	47		VRR
22		GND	54		VTT
23		GND	55		VTT
24		D_VCC	56		GND
25		D_VCC	57		GND
26	I	JTAG_TMS			

Notes:

- The UART\_TXD pin shall be used as data input for using @ANY2400-2 as its RF terminal unit. UART\_RXD pin shall operate as output.
- Most signals can be configured as I/O pins with or without internal pull-up resistor.
- Using ferrite bead and 1  $\mu$ F capacitor located closely to the power supply pin is recommended.

## 2.3 Mounting Information

Figure 3 @ANY-BRICK PCB picture as a reference for applications

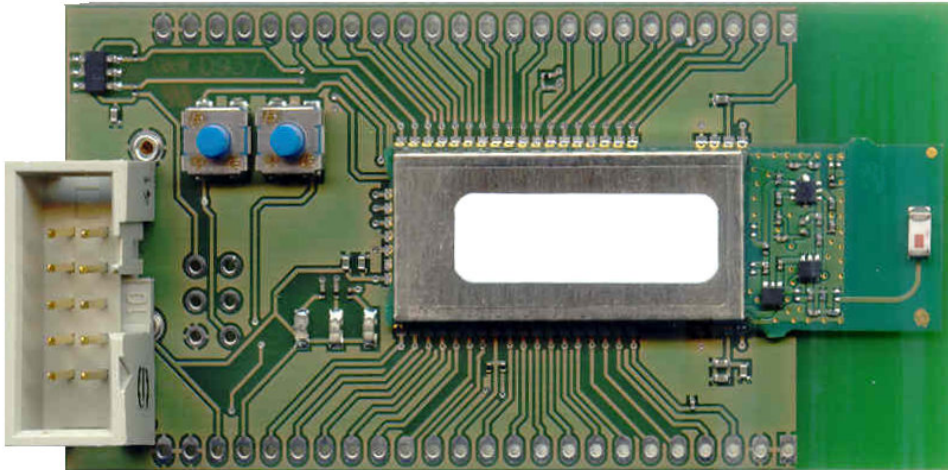

Several factors may affect the proper operation, such as the environment surrounding the module and especially the antenna. The module's antenna is a ceramic design, which provides a radiating structure if the environment and design does not change the near-field of the antenna with metallic or capacitive elements. The critical area is limited by about two to four wavelengths, which is roughly in a radius of 1.5 meters.

Following these tips will improve the radiating performance:

- Avoid metal as much as possible
- Avoid placing high profiled elements close to the antenna
- Placing many thin vias through all the carrier PCB connecting metal to ground helps avoid resonance effects and provide a low impedance connection to ground potential
- Place RF parts far off from switching circuitry to avoid intermodulations
- Metalize board edges on top and bottom layer and place vias there to connect the layers for eliminating board edge radiations

For a proper PCB layout:

- Keep fast switching signals as far away as possible from the non-shielded area (right side from the AT86RF231)
- Remove any metal below and around the antenna section
- Place the module at the edge of your carrier board
- Vias and wires below the module are NOT allowed
- Connect RF ground pins to low ohmic ground, place vias right next to the pin connection if needed
- Use ferrite beads on power supply lines for proper and stable RF radiation (60dB above 100kHz)

Figure 4 Pad layout

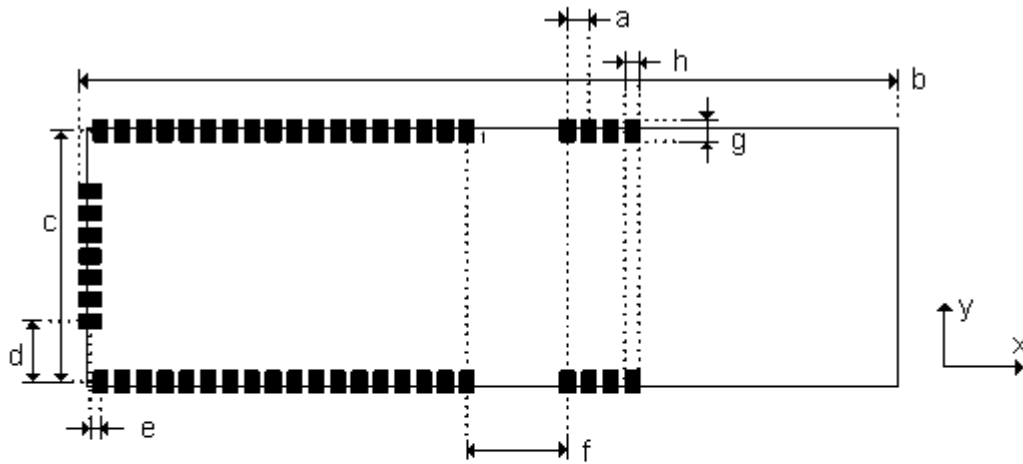

All values in [mm]

a	1	distance from pad to pad (center)
b	41	module's x dimension
c	13,2	pad center to pad center in y direction (pin 18 to pin 26)
d	3,6	pad centers y distance (pin 25 to pin 26 and pin 18 to pin 19)
e	0,75	pad centers x distance (pin 25 to pin 26 and pin 18 to pin 19)
f	5	pad center distance (pin 43 to pin 44 and pin 1 to pin 57)
g	1	pad size in y direction
h	0,8	pad size in x direction

**A.N. Solutions GmbH offers available footprints for Altium Designer (S09) and KiCad on request.**



## 2.4 Soldering Profile

The J-STD-020D-compliant soldering profile is recommended.

Table 6 J-STD-020D Profile

Feature	Green Package
Average ramp-up rate (217 °C to peak)	3 °C/s max.
Preheat temperature 175 °C ± 25 °C	180 s max.
Temperature maintained above 217 °C	60 s to 150 s
Time within 5 °C of actual peak temperature	20 s to 40 s
Peak temperature range	8 minutes max.
Ramp-down rate	6 °C/s max.

Note: The package is backward compatible with Pb/Sn soldering profile

Figure 5 EMS Reference soldering profile

ECOV® SuperM.O.L.E.(r) Gold SPC V5.22aa - kundenspez\_Profile.mpc  
Id. Datei: SM\_E91824\_000104 Datum: 24/01/07

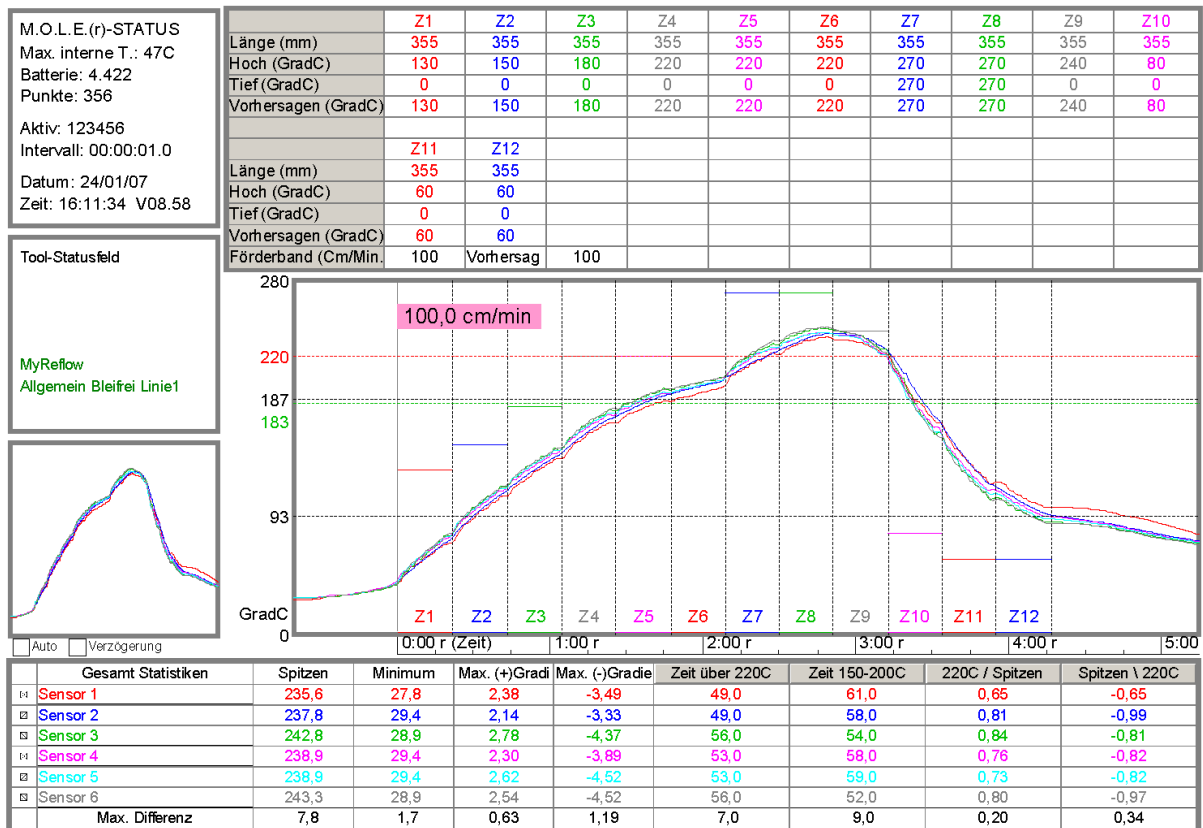

## 2.5 Typical Reference Schematic

Figure 6 @ANY-BRICK schematic as a reference for battery operation

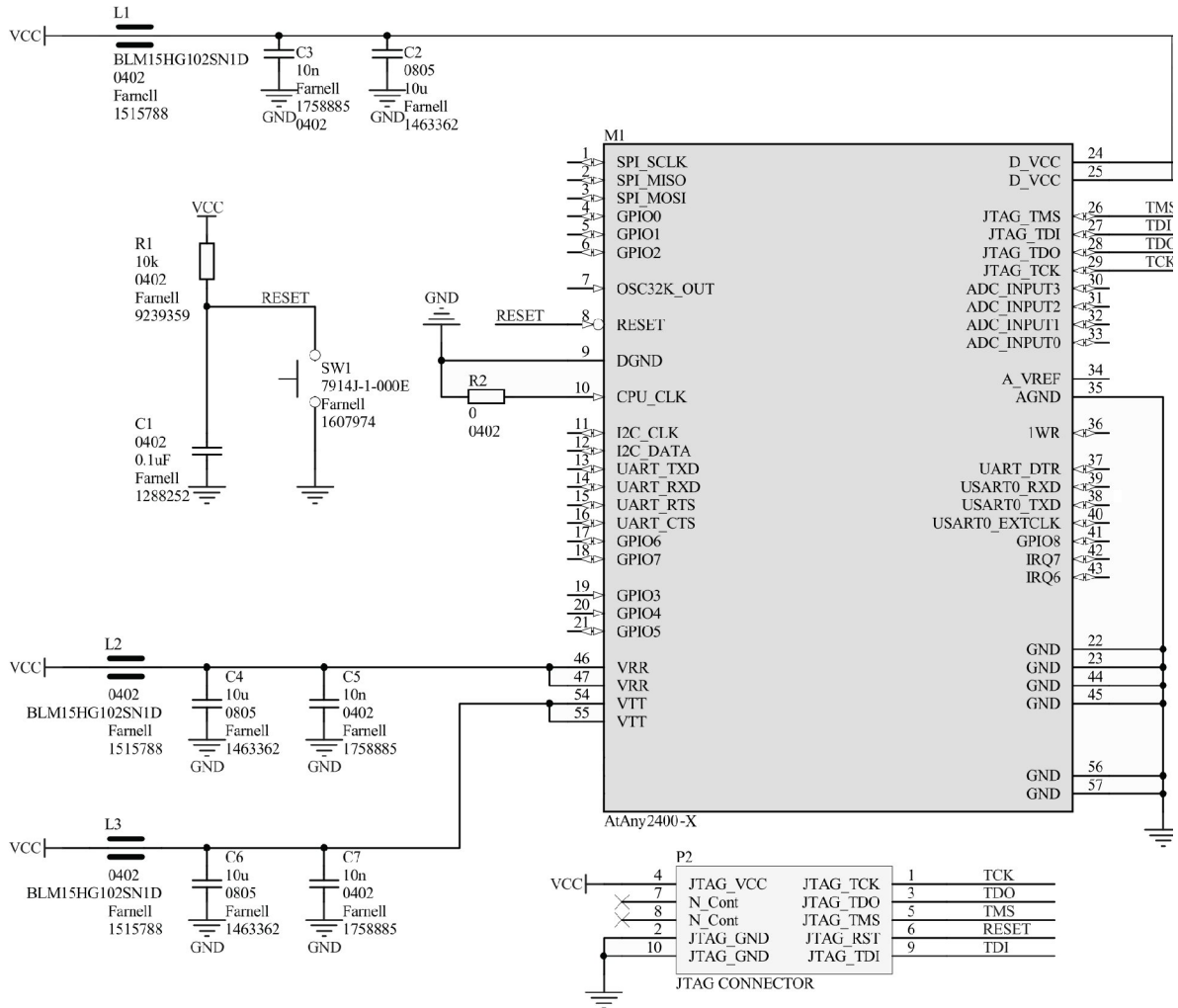

The reference schematic in Figure 6 shows one kind of AT-ANY2400 module as M1. This can be AT-ANY2400-1 or -2. All VDD connections are supplied with its own filtering structure. The digital domain concerning the module pins 24 and 25 are on the opposite edge of the module as the antenna or antenna connector is placed, supply pins 46,47 and 54,55 are placed as close as possible towards the RF section but on opposite edges of the module. This constellation allows providing a homogeneous ground and VDD connection as independent of the carrier board as possible. Nevertheless due to the large used area of the module, each module's side can be a victim of distortion aggressors, so each side's power supply has to be filtered.

Figure 6 shows a combination of one choke and two capacitors used per supply pin couple. Additionally with R2 it shows a ground connection leading from pin 9 to pin 10. Due to a wire on the module identified as potential crosstalk victim, the zero ohm resistor works as a load impedance.

Each board even minimalistic boards shall feature a JTAG connector for easy on-board programming or firmware updates. In the worst case the used microcontroller can be programmed in a way any boot loading or ISP strategies would fail, except the JTAG interface. Additional firmware loading strategies may be applied.



## 2.6 Software and Programming Options

Due to the flexibility of AVR microcontrollers and the fact that the module provides programming interfaces as JTAG and ISP, the customer is able to use the full Atmel AVR tool chain to customize the module's MCU.

Software options are:

- 1 *ANS Smart MAC Suite Base* is pre-programmed on development kits in the current available version\*
- 2 *ANS Smart MAC Suite Pro* is optional available. It provides more features (compare the development documentation) and is delivered in two versions: *standalone* or *library*. Using the library version, it is possible to add own code to extend functionality further.
- 3 Atmel's Zigbee Pro stack *Bitcloud* can be used if adapted to the modules target carrier board
- 4 Atmel's IEEE802.15.4 open source MAC layer can be used if adapted to the modules target carrier board
- 5 *ANS Hardware Abstraction Layer library* is optional available

All the software and its status may change on demand of A.N. Solutions GmbH.

Most of the possible software options need different additional programming tools. For more information please be referred to the documentation of A.N.Solution's Development Kit.

Table 7 additional programming tools

Software option	Programming tools
1	Boot loader via serial port, ATMEL-JTAG-MKII
2	Boot loader via serial port, ATMEL-JTAG-MKII
3	ATMEL-JTAG-MKII
4	ATMEL-JTAG-MKII
5	Boot loader via serial port, ATMEL-JTAG-MKII



## 3 Ordering Information

Part number: AT-ANY2400-2  
Description: IEEE802.15.4-2.4GHz module  
Shipping variants: Waffle-Pack with 40 units/waffle  
T&R on demand

### Disclaimer

A.N. Solutions believes that all information is correct and accurate at the time of issue. A.N. Solutions reserves the right to make changes to this product without prior notice. Please visit A.N. Solutions website for the latest available version.

A.N. Solutions does not assume any responsibility for the use of the described product or convey any license under its patent rights.

A.N. Solutions warrants performance of its hardware products to the specifications applicable at the time of sale in accordance with A.N. Solutions standard warranty. Testing and other quality control techniques are used to the extent A.N. Solutions deems necessary to support this warranty. Except where mandated by government requirements, testing of all parameters of each product is not necessarily performed.

### Trademarks

AT-ANY, @ANY and related naming as well as A.N. Solutions logo are trademarks of A.N. Solutions GmbH. All other product names, trade names, trademarks, logos or service names are the property of their respective owners.

### Technical Support

Technical support is provided by A.N. Solutions GmbH on demand and in accordance to service conditions agreed.

E-mail: [support@an-solutions.de](mailto:support@an-solutions.de)

Please refer to Support Terms and Conditions for full details.

### Contact Information

#### **A.N. Solutions GmbH**

Am Brauhaus 12  
01099, Dresden,  
Germany  
Tel: +49 351 8134 228  
Fax: +49 351 8134 200

Office hours: 8:00am - 5:00pm (Central European Time)

© 2011 A.N. Solutions All rights reserved.

No part of the contents of this manual may be transmitted or reproduced in any form or by any means without the written permission of A.N. Solutions.